

Handwheels with retractable handle

Aluminium, Handle locked

SPECIFICATION

Type

- Type **R**: with retractable handle

Bore codes

- Version **B**: without keyway
- Version **K**: with keyway

Aluminium pressure die casting

- Hub machined
- Rim turned
- plastic coated

black, RAL 9005, textured finish **SW**
silver, RAL 9006, textured finish **SR**

Rim concentric and square to bore < 0.4

Retractable handles GN 798.3 (see page 586)

Plastic, Technopolymer
black, matt

Retracting mechanism
Steel, blackened



INFORMATION

The handle in these disc handwheels is locked in a conical bore in the operating position.

For reversal, it must first be pulled from the cone in axial direction. A pressure spring holds the handle in both positions. When swung out, it automatically engages again.

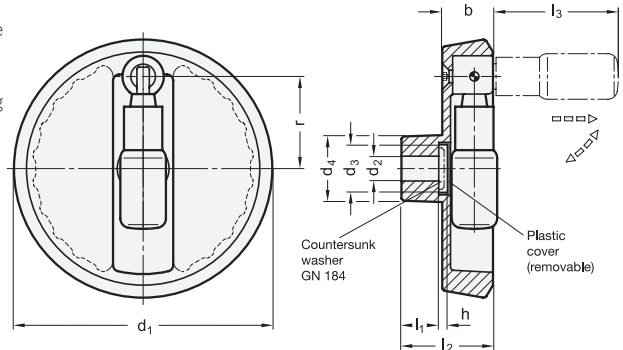

* Complete with colour index of the Handwheels (SW or SR)

SW **SR**
RAL9005 RAL9006

GN 923.3

Description	d1	d2 H7	d3	d4	b	h	l1	l2 ≈	l3 ≈	r	Ø Handle	Recommended countersunk washer	⚖
GN 923.3-100-B10-R-*	100	10	18	28	20	4	17	39	56.5	35	18	GN 184-16	252
GN 923.3-100-K10-R-*	100	10	18	28	20	4	17	39	56.5	35	18	GN 184-16	240
GN 923.3-100-B12-R-*	100	12	18	28	20	4	17	39	56.5	35	18	GN 184-16	260
GN 923.3-100-K12-R-*	100	12	18	28	20	4	17	39	56.5	35	18	GN 184-16	260
GN 923.3-125-B12-R-*	125	12	23	31	24.5	4	18	45	60.5	44.5	22	GN 184-22	460
GN 923.3-125-K12-R-*	125	12	23	31	24.5	4	18	45	60.5	44.5	22	GN 184-22	460
GN 923.3-125-B14-R-*	125	14	23	31	24.5	4	18	45	60.5	44.5	22	GN 184-22	440
GN 923.3-125-K14-R-*	125	14	23	31	24.5	4	18	45	60.5	44.5	22	GN 184-22	440
GN 923.3-140-B14-R-*	140	14	23	36	26	4	19	47	75.5	52	24	GN 184-22	590
GN 923.3-140-K14-R-*	140	14	23	36	26	4	19	47	75.5	52	24	GN 184-22	590
GN 923.3-140-B16-R-*	140	16	23	36	26	4	19	47	75.5	52	24	GN 184-22	550
GN 923.3-140-K16-R-*	140	16	23	36	26	4	19	47	75.5	52	24	GN 184-22	540
GN 923.3-160-B14-R-*	160	14	23	36	26	4	20	48	75.5	61	24	GN 184-22	740
GN 923.3-160-K14-R-*	160	14	23	36	26	4	20	48	75.5	61	24	GN 184-22	740
GN 923.3-160-B16-R-*	160	16	23	36	26	4	20	48	75.5	61	24	GN 184-22	730
GN 923.3-160-K16-R-*	160	16	23	36	26	4	20	48	75.5	61	24	GN 184-22	730
GN 923.3-200-B18-R-*	200	18	23	42	27	4	24	53	85.5	80.5	25	GN 184-22	1100
GN 923.3-200-K18-R-*	200	18	23	42	27	4	24	53	85.5	80.5	25	GN 184-22	1100
GN 923.3-200-B20-R-*	200	20	23	42	27	4	24	53	85.5	80.5	25	GN 184-22	921
GN 923.3-200-K20-R-*	200	20	23	42	27	4	24	53	85.5	80.5	25	GN 184-22	915